

# ACCESSORY SETUP INSTRUCTIONS

**HAND GUARD ASSY PN: 6AQV-804600-6000**

VALID FOR: CF400-8

**BEFORE YOU BEGIN:** Read and understand the instructions before starting any work. Make sure that all parts are ready and that you have all the tools required for assembly.

**NOTE:** CFMOTO shall not be liable for any damage caused by incorrect assembly. CFMOTO recommends that all original accessories be assembled by an authorized CFMOTO dealer.

Before assembly, park the vehicle on a flat surface and turn off the vehicle.

**Zhejiang CFMOTO Power Co., Ltd.** All rights reserved. Reproduction of this document, even in part, as well as copying of all kinds, is permitted only with the express written permission of the copyright owner.

## MEANING OF SYMBOLS



- Indicates information with more details or tips.



- Indicates information of warning or danger.

## PART LIST:

S/N	PART NAME	PART NUMBER	QTY.	DESCRIPTION
1	HAND GUARD ASSY	6AQV-804600-6000	1	Picture is for structure reference only.
2	LH HAND GUARD	6AQV-804601-6000	1	
3	RH HAND GUARD	6AQV-804602-6000	1	
4	LH HAND GUARD BOW	6AQV-804603-6000	1	
5	RH HAND GUARD BOW	6AQV-804604-6000	1	
6	BALANCE BLOCK	6AQV-804605-6000	1	
7	BUSHING TUBE 1	6AQV-804805-6000	1	
8	BUSHING TUBE 2	6AQV-804804-6000	1	
9	HANDLEBAR CLAMP	6AQV-804806-6000	2	
10	NYLON CLIP	6AQV-804807-6000	4	
11	LH ADAPTOR BRACKET	6AQV-804808-6000	1	
12	RH ADAPTOR BRACKET	6AQV-804809-6000	1	
13	HANDLEBER CLAMP COVER	6AQV-804811-6000	2	
14	INNER HEX SCREW M6×25	6AQV-804600-6000-20	2	
15	INNER HEX SCREW M8×18	6AQV-804600-6000-21	2	
16	SCREW ST4.2×9.5	6AQV-804600-6000-22	4	
17	INNER HEX SCREW M6×20	6AQV-804600-6000-23	4	
18	INNER HEX SUNK SCREW M8×70	6AQV-804600-6000-24	2	

## ACCESSORY SETUP INSTRUCTIONS

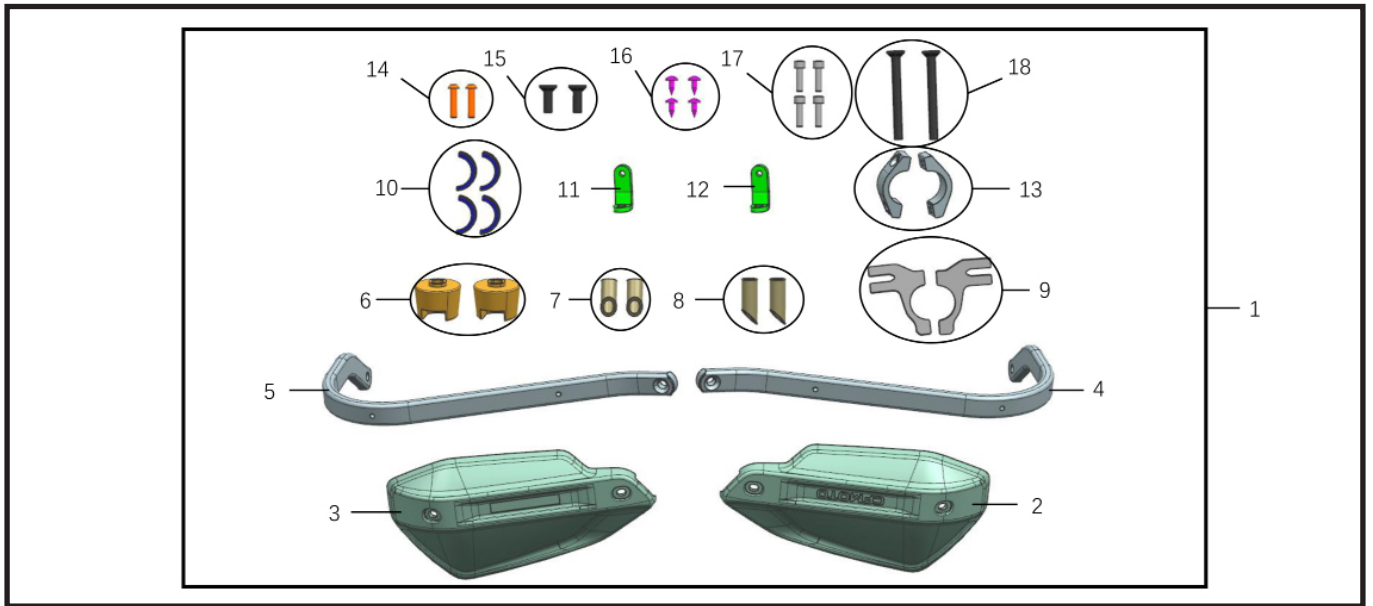

### TOOL LIST:

ITEM	DESCRIPTION	REMARK
1	s=5 INNER HEX WRENCH	Recommended Tools
2	SLEEVE 8mm	
3	CROSS SCREWDRIVER	
4	CUTTER KNIFE	
5	PROTECTIVE GLOVES	

**WORK**

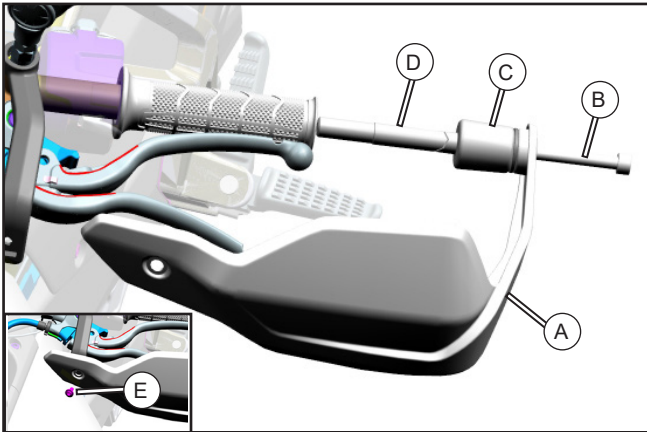

- // Loosen and remove the screw (E).
- // Loosen the screw (B), then take out the screw (B), the balance block (C) and the bushing (D).

**i** - The disassembled method on both the left and right sides is the same.

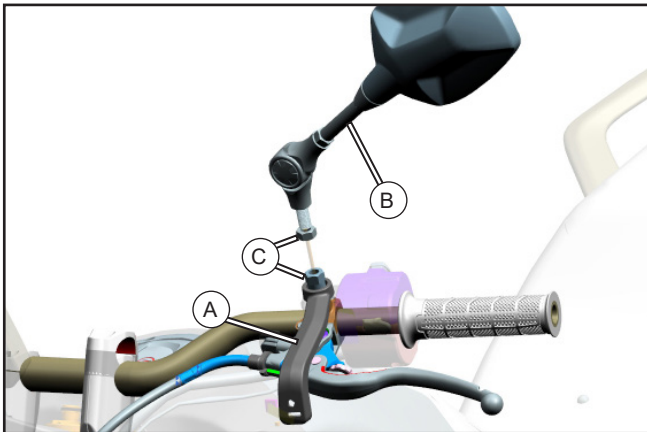

- // Loosen the two nuts (C).
- // Remove the rearview mirror (B), then remove the adapter bracket (A).

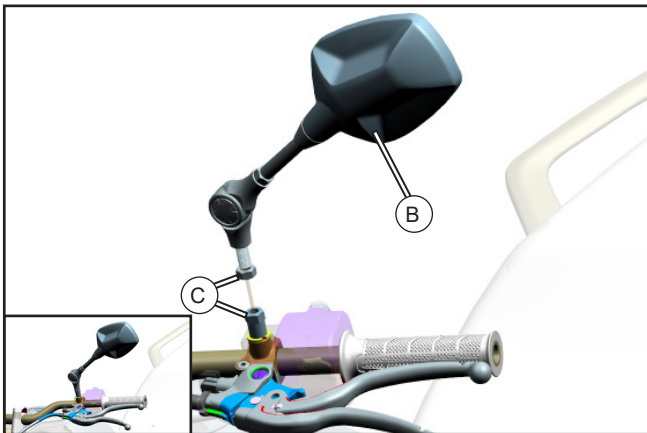

- // Place the rearview mirror (B) in the corresponding position then bring the two locking nuts (C) into the assembly for securing.

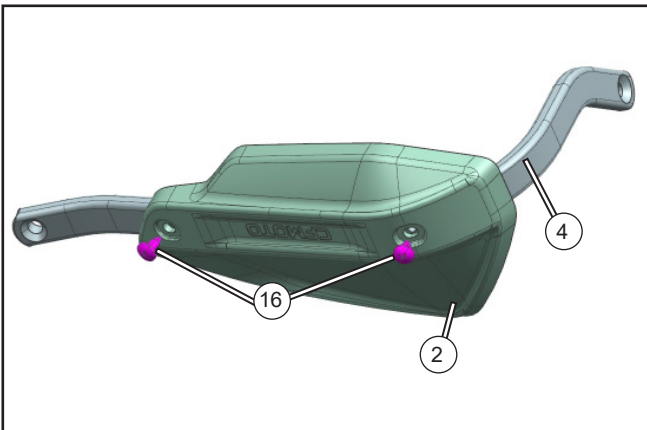

- // Assemble the LH hand guard (2) and the LH handguard bow (4) with the two ST4.2x9.5 screws (16).

**i** - The RH hand guard (3) and the RH handguard bow (5) on the right side are assembled in the same method.

**WORK**

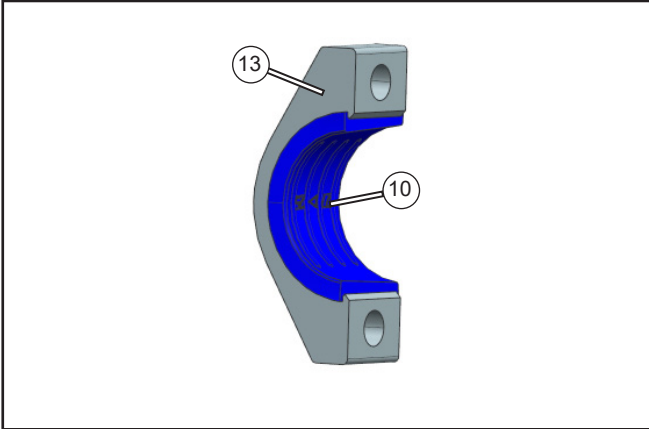

// Place the nylon clip (10) onto the corresponding position of the handlebar clamp cover (13) as shown.

**i** - The assembled method on both the left and right sides is the same.

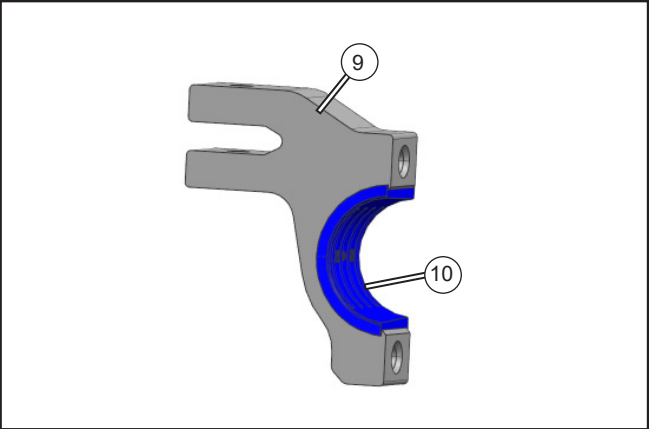

// Place the nylon clip (10) onto the corresponding position of the handlebar clamp (9) as shown.

**i** - The assembled method on both the left and right sides is the same.

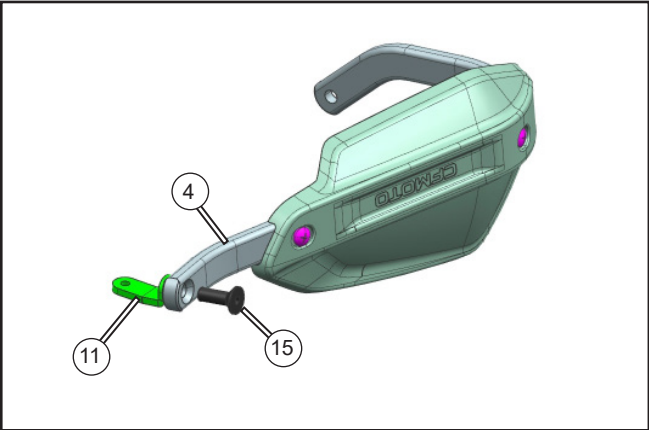

// Place the LH adapter bracket (11) and the LH handguard bow (4) in the corresponding position.  
 // Bring the inner hex screw M8×18 (15) into the assembly for securing as shown.

**i** - The assembled method on both the left and right sides is the same.

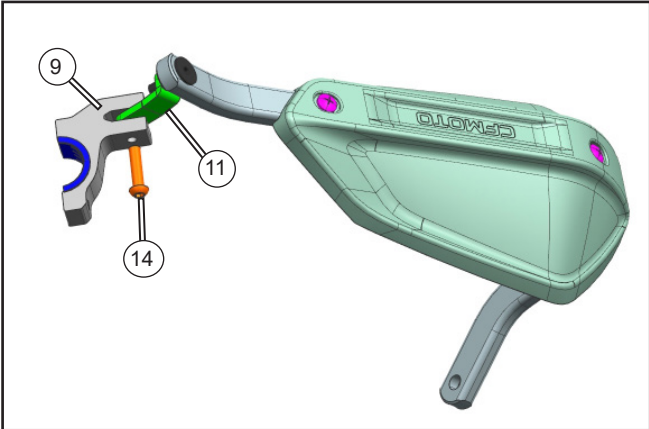

// Place the handlebar clamp (9) in the corresponding position.  
 // Bring the inner hex screw M6×25 (14) into the assembly for securing as shown.

**i** - The assembled method on both the left and right sides is the same.

**WORK**

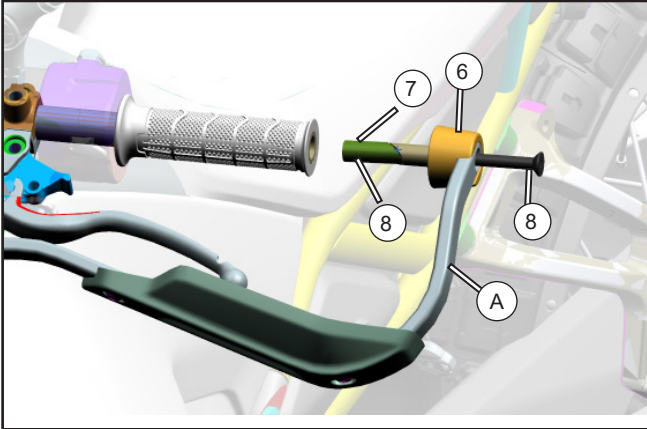

- // Place the hand guard assembly (A) in the corresponding position as shown.
- // Bring in one inner hex sunk screw (8), and preload the bushing tube I (7) or bushing tube II (8) with the balance block (6) and the LH handguard bow assembly.
- // Insert the bushing tube assembly into the grip assembly as shown.

**i** - The assembled method on both the left and right sides is the same.  
 - The bushing tube I (7) is adapted to the 450MT model;  
 - The bushing tube II (8) is adapted to the 800MT-X model.

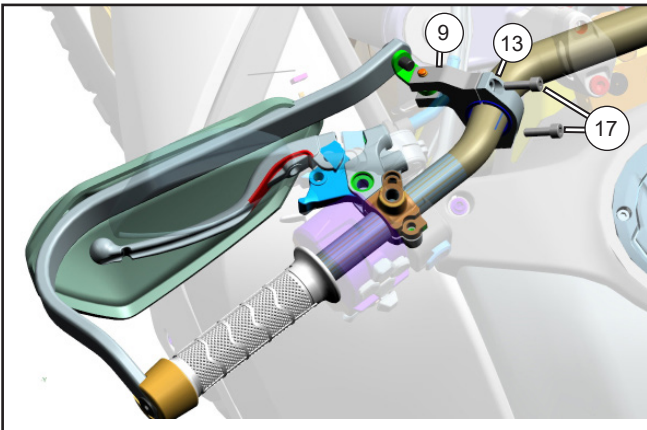

- // Place the handlebar clamp cover (13) in the corresponding position as shown.
- // Bring in two inner hex screws M6 × 20 (17), and pre-tighten the handlebar clamp (9).

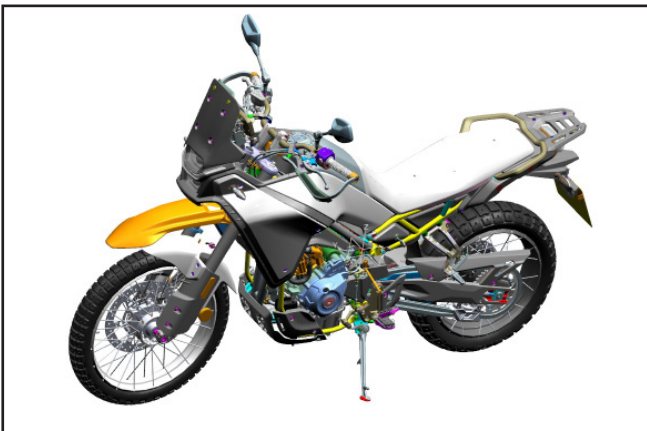

- // Fasten all screws.
- // Assembly is complete.