

## ACCESSORY SETUP INSTRUCTION

### AIR INTAKE SNORKEL -- PN 5ASV-803100-6000

VALID FOR: MY2021 and Newer UFORCE 600

**BEFORE YOU BEGIN:** Read and understand the instructions before starting any work. Make sure that all parts are ready and that you have all the tools required for assembly.

**NOTE:** CFMOTO shall not be liable for any damage caused by incorrect assembly. CFMOTO recommends that all original accessories be assembled by an authorized CFMOTO dealer.

Before assembly, park the vehicle on a flat surface, put the transmission gear into Park (P) and turn off the key switch.

**Zhejiang CFMOTO Power Co., Ltd.** All rights reserved. Reproduction of this document, even in part, as well as copying of all kinds, is permitted only with the express written permission of the copyright owner.

## MEANING OF SYMBOLS

 - Indicates information with more details or tips.

 - Indicates information of warning or danger.

## PARTS LIST:

ITEM	PART NAME	PART NUMBER	QTY.	REMARK
1	AIR INLET PIPE, CVT	5ASV-803110-6000	1	
2	AIR INLET PIPE, AIR FILTER	5ASV-803120-6000	1	
3	CONNECTING PIPE	5HY#-803003-1200	2	
4	CONNECTING PLATE	5HY#-803004-1200	2	
5	NUT	5HY#-803007-1200	8	
6	CLAMP	30604-301300	4	
7	SELF-TAPPING SCREW	30110-480190070	8	
8	SCREEN	5HY#-803008-1200	2	
9	CONNECTOR, AIR INLET PORT	5HY0-002102	2	
10	AIR INTAKE SNORKEL	5ASV-803100-6000	1	

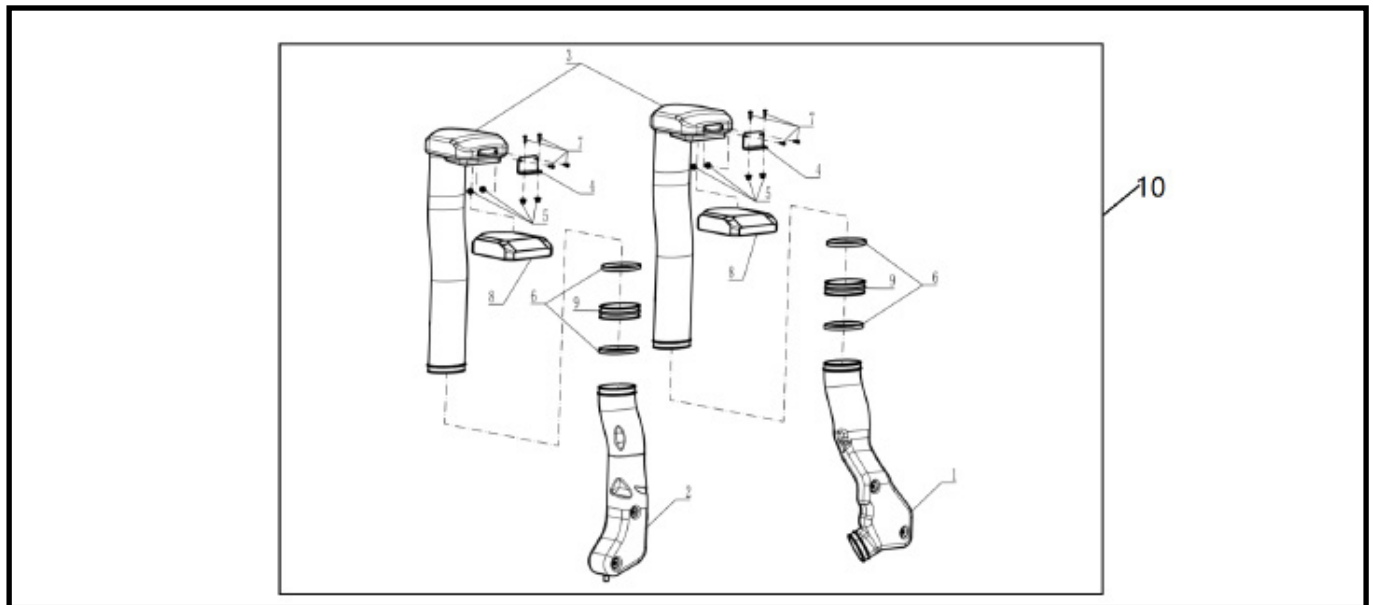

## TOOL LIST:

ITEM	DESCRIPTION	QTY.	REMARK
1	PROTECTIVE GLOVES	1	Recommended tools
2	PHILIPS SCREWDRIVER	1	

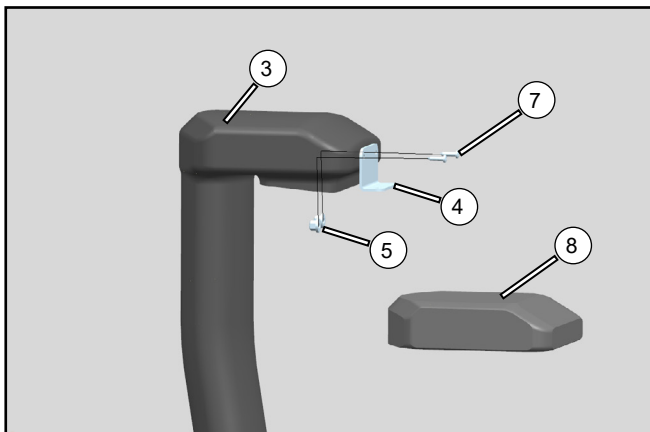
**ASSEMBLY and INSTALLATION**

- // Secure the connecting plates (4) to the connecting pipes (3) with screws (7) and nuts (5).
- // Install the screens (8) into the connecting pipes (3).

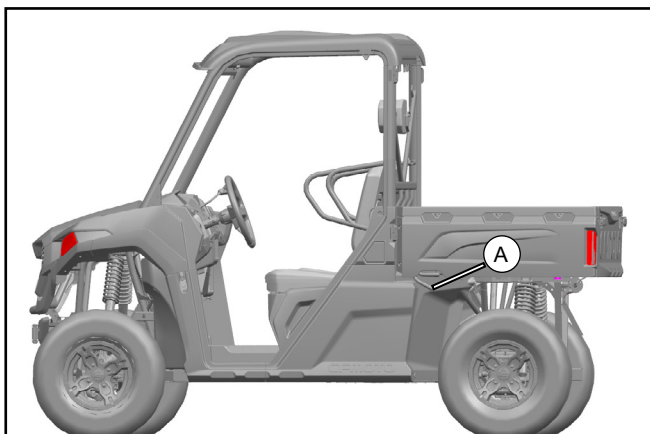

- // Open the cargo box by pulling the handle (A).

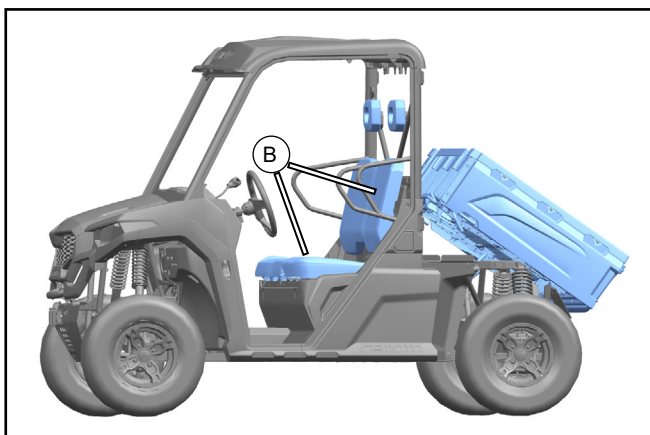

- // Remove the driver and passenger seat back assemblies (B).

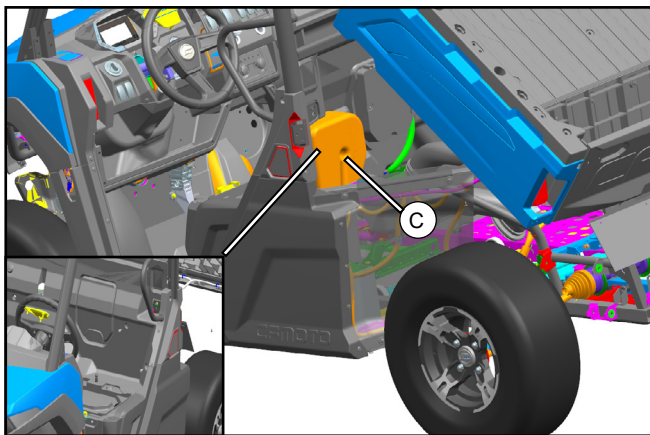

- // Open the driver side cover plate and remove the CVT inlet box (C). Retain the connecting components.

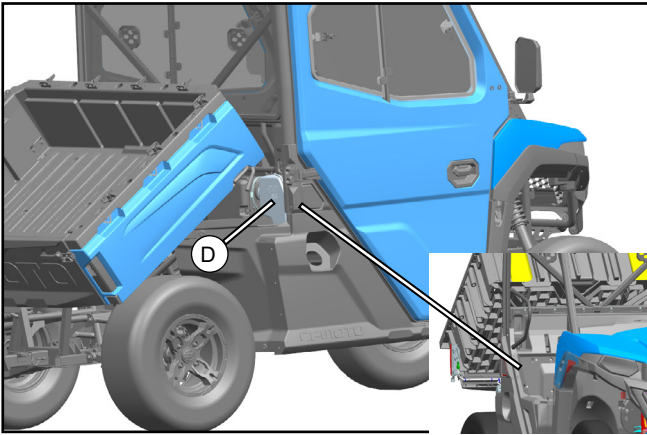
**ASSEMBLY and INSTALLATION**

// Open the passenger side cover plate and remove the primary filter box (D) attached the air filter housing. Retain the connecting components.

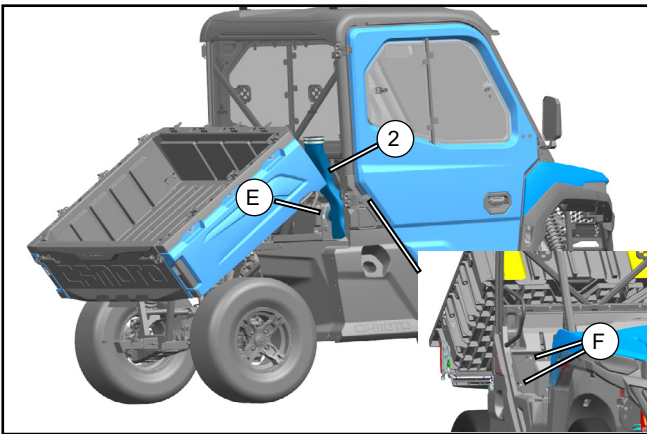

// Place air filter inlet pipe (2) into position on the air filter housing, then secure it with existing clamp 100-130 (E).  
 // Reinstall the passenger side cover plate, and fasten it with removed screws (F).

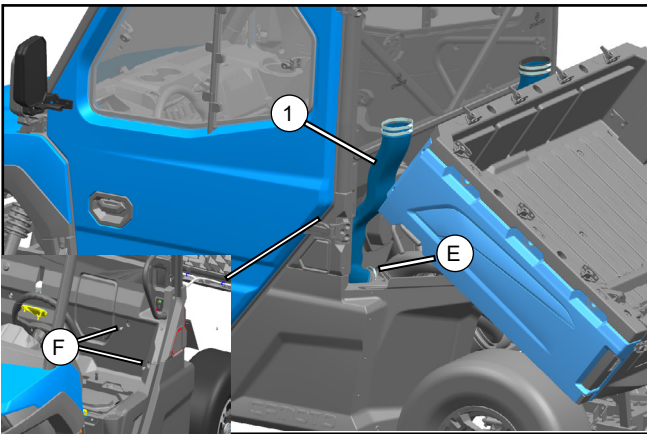

// Place CVT inlet pipe (1) into position on CVT inlet box , then secure it with existing clamp 100-130 (E).  
 // Reinstall the driver side cover plate, and fasten it with removed screws (F).

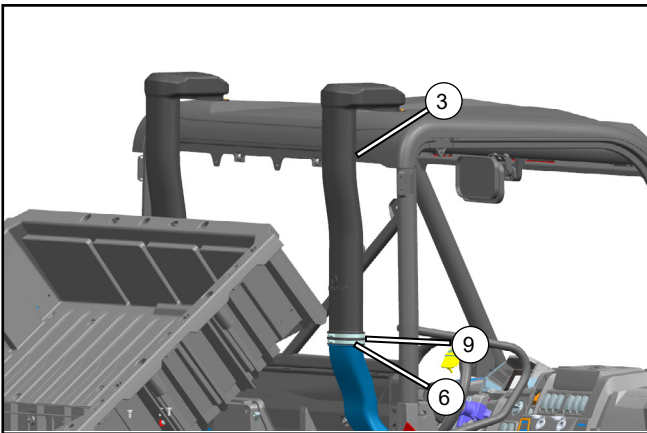

// Install connecting pipe (3) to the air filter inlet using connector (9), and secure with clamps (6).

## ASSEMBLY and INSTALLATION

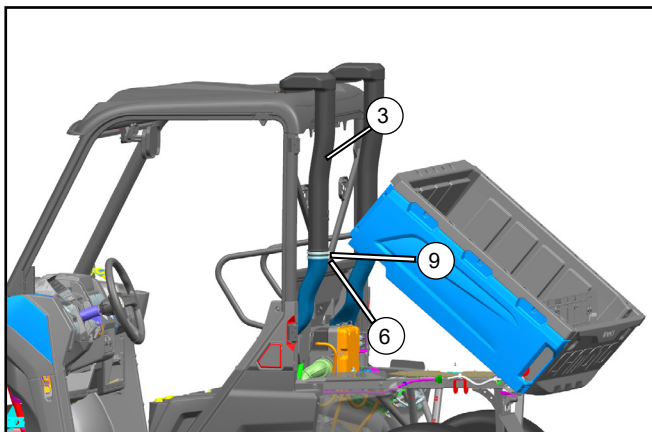

// Install connecting pipe (3) to the CVT air inlet using connector (9), and secure with clamps (6).

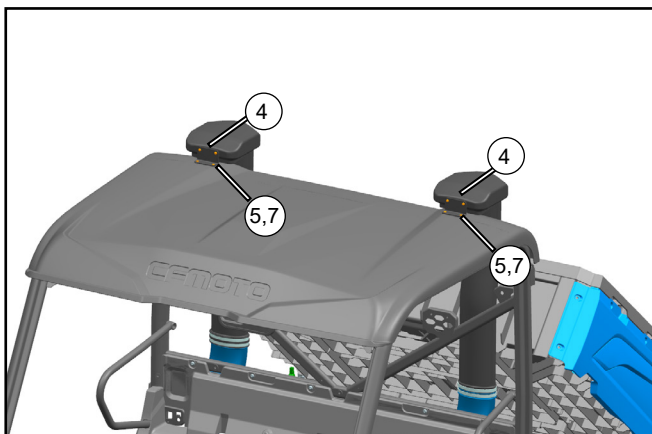

// Secure the connecting pipes (3) to the top roof with connecting plates (4), screws (7) and nuts (5).

