

ACCESSORY SETUP INSTRUCTION

HALF WINDSHIELD ASSEMBLY -- PN 5ASV-805300-6000

VALID FOR: MY2021 and Newer UFORCE 600 UTVs

BEFORE YOU BEGIN: Read and understand the instructions before starting any work. Make sure that all parts are ready and that you have all the tools required for assembly.

NOTE: CFMOTO shall not be liable for any damage caused by incorrect assembly. CFMOTO recommends that all original accessories be assembled by an authorized CFMOTO dealer.

Before assembly, park the vehicle on a flat surface, put the transmission gear into Park (P) and turn off the key switch.

Zhejiang CFMOTO Power Co., Ltd. All rights reserved. Reproduction of this document, even in part, as well as copying of all kinds, is permitted only with the express written permission of the copyright owner.

MEANING OF SYMBOLS

 - Indicates information with more details or tips.

 - Indicates information of warning or danger.

PARTS LIST:

ITEM	PART NAME	PART NUMBER	QTY.	REMARK
1	HALF WINDSHIELD ASSEMBLY	5ASV-805300-6000	1	
2	HALF WINDSHIELD	5ASV-805311-6000	1	
3	CLAMP	5ASV-804100-6000	2	
4	SEAL STRIP	5ASV-805300-6000-20	1	
/	THREAD LOCKER	/	1	

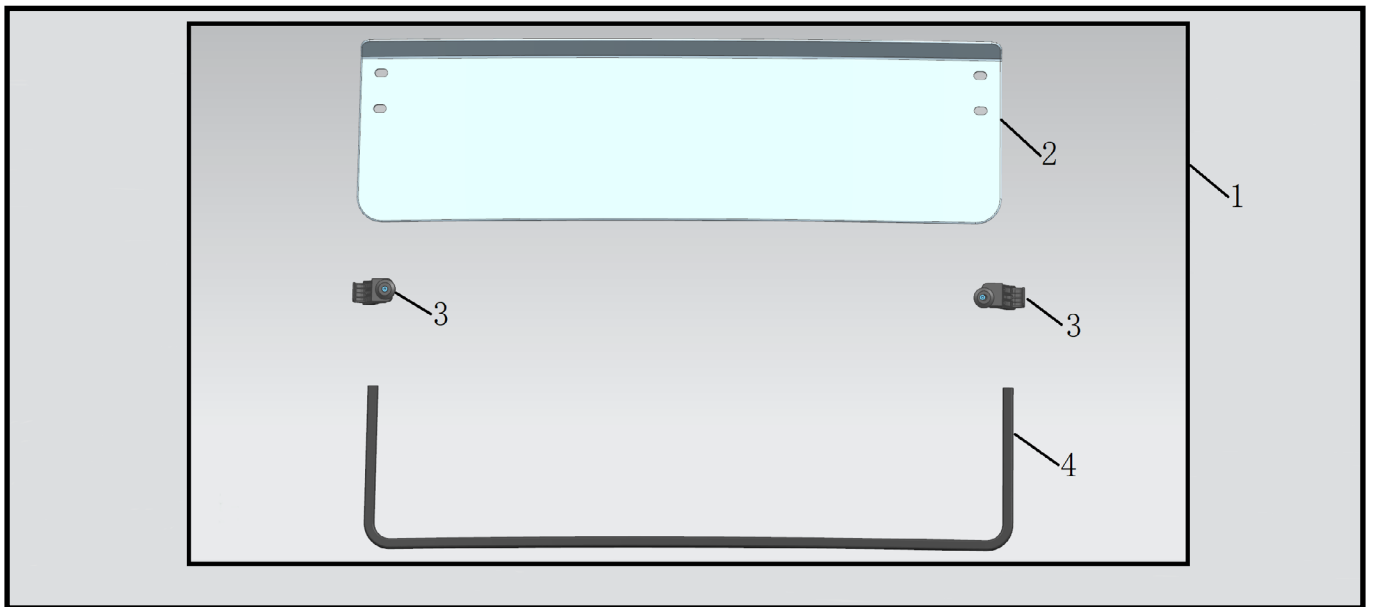

TOOL LIST:

ITEM	DESCRIPTION	QTY.	REMARK
1	PROTECTIVE GLOVES	1	Recommended Tools
2	4mm ALLEN WRENCH	1	

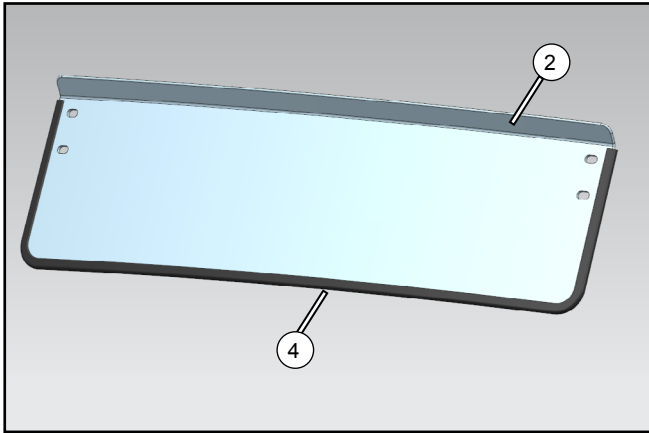
ASSEMBLY and INSTALLATION

// Install seal strip (4) to the half windshield (2).

i Remove the protective film from the windshield surface.

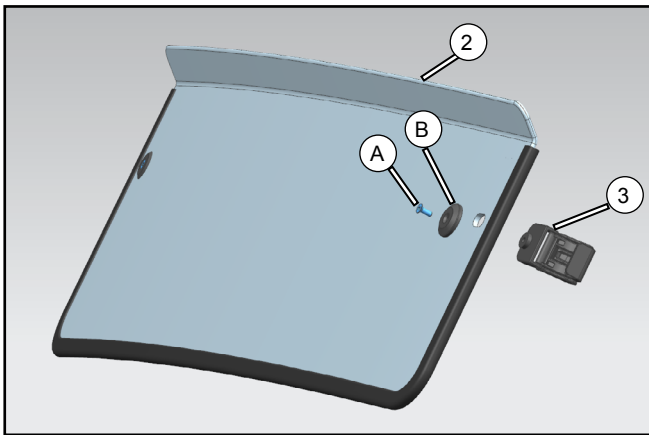

// Remove the gaskets (B) and screws (A) from the clamps (3), then install the clamps (3) onto the half windshield (2) with the gaskets (B) and screws (A). *Do not fully tighten bolts at this time.*

i Apply some thread locker to the screw.

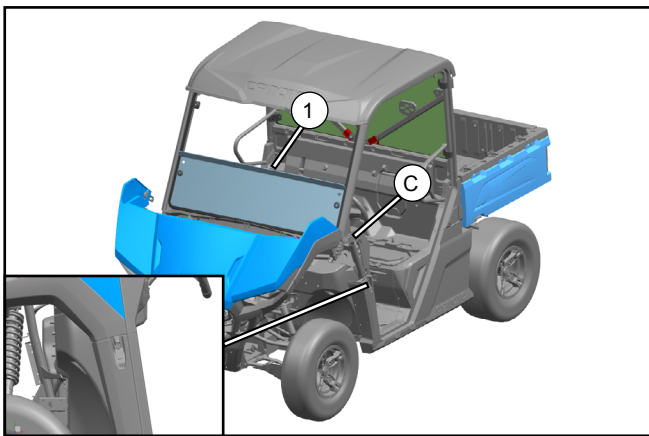

// Open the front cover (C).

// Position the front windshield assembly (1) on the top bar front assembly as shown to determine the clamp positions.

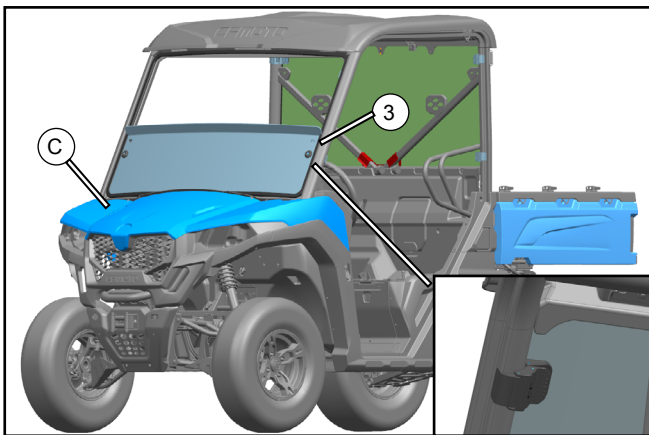

// Assemble each side with clamps (3). Tighten the screws sufficiently, using care not to over-tighten.

// Close the front cover (C).