

# ACCESSORY SETUP INSTRUCTION

## WIPER AND WASHER ASSY -- PN: 5HY0-806130

Apply to: UFORCE 1000, UFORCE 1000 XL

**BEFORE YOU BEGIN:** Read and understand this instruction before starting any work. Make sure that all parts are read and that you have all the tools required for assembly.

**NOTE:** CFMOTO shall not be liable for any damage caused by incorrect assembly. CFMOTO recommends that all original accessories be assembled by an authorized CFMOTO dealer. Before assembly, park the vehicle on a flat surface, put the transmission gear into Park (P) and turn off the key switch.

**Zhejiang CFMOTO Power Co., Ltd.** All rights reserved. Reproduction of this document, even in part, as well as copying of all kinds, is permitted only with the express written permission of the copyright owner.

## MEANING OF SYMBOLS



- Indicates information with more details or tips.



- Indicates information of warning or danger.

## PARTS LIST:

ITEM	PART NAME	PART NUMBER	QTY	REMARK
1	WIPER MOTOR	5HY0-806522	1	For structure reference only
2	WASHER TANK	5HY0-806524	1	
3	WIPER BLADE	5HY0-806521	2	
4	WIPER ARM	5HY0-806520	1	
5	HARNES AND WASHER TUBE	5HY0-806523	1	
6	WASHER TUBE ADAPTER	5HY0-806525	1	
7	M6 NUTCLAMP	8030-040800-00001	2	
8	M6x16 BOLT	30006-060016810	2	
9	3M DOUBLE FACED ADHESIVE TAPE	5HY0-806130-20	1	
10	WIPER AND WASHER ASSY	5HY0-806130	1	



## TOOL LIST:

ITEM	TOOL NAME	QTY	REMARK
1	PROTECTIVE GLOVES	1	Recommended Tools
2	φ16 DRILL	1	
3	φ8 DRILL	1	
4	T-SHAPED INSERT S10	1	
5	OPEN-ENDED WRENCH S27-S29	1	
6	OPEN-ENDED WRENCH S13-S15	1	
7	CUTTER	1	

## ASSEMBLY and INSTALLATION

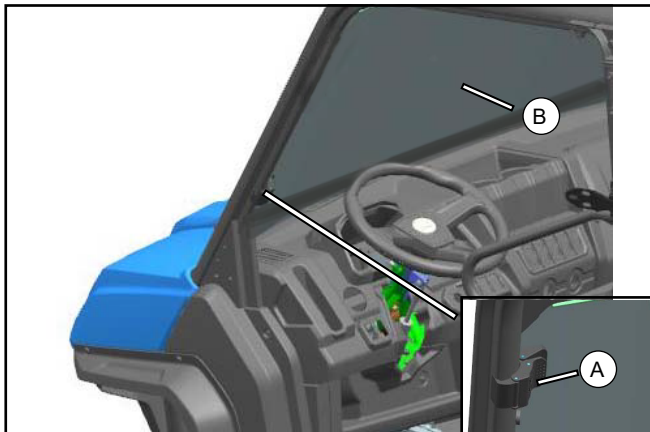

// Loose 2 clamps (A) of front Glass windshield, Remove 2 brackets located at the top with thumb screws. Remove front windshield (B).

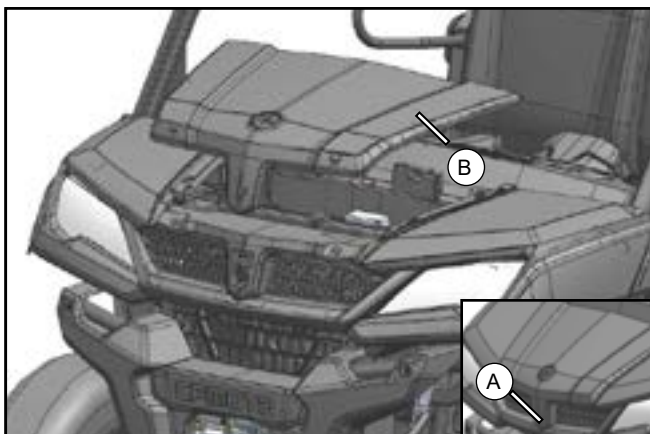

// Take out the insert of front hood from (A) place, Remove front hood (B)

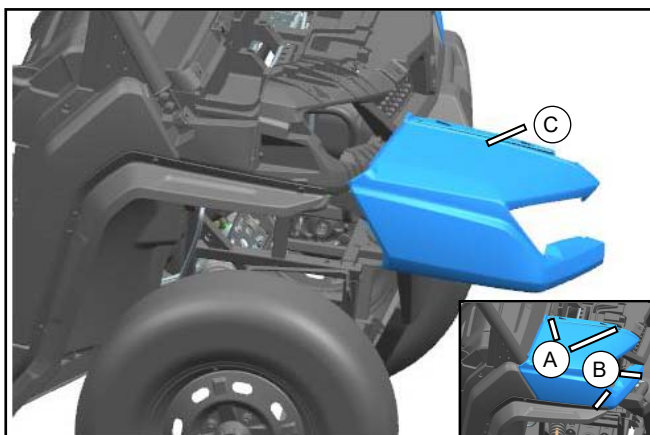

// Dis-assemble 2 units M6x12 Bolt (A) and 4 Expansion Screws (B), and Remove Panel (C).

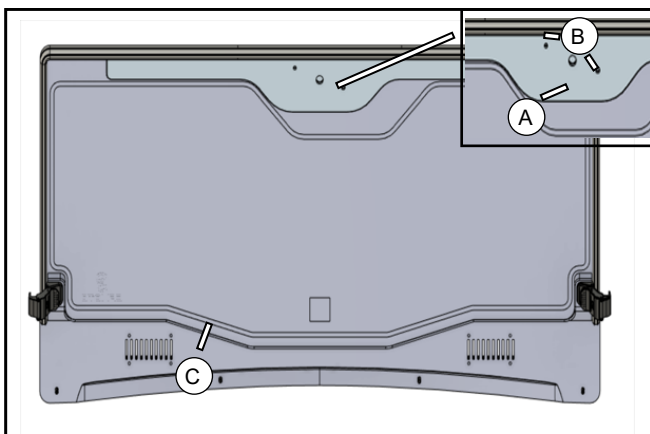

( C ), Drill a  $\phi 16$  hole at position (A) , and Drill  $\phi 8$  holes at position (B).

**i** - There is no Glass behind the holes that are drilled out

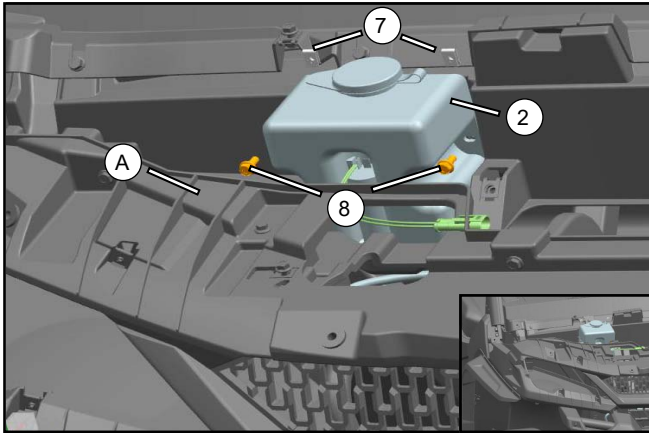
**ASSEMBLY and INSTALLATION**

// Insert M6 Nut Clamp (7) into the slot of Front Fender (A), use M6x16 Bolt (8) to tighten Washer Tank (2) on Front Fender as the left illustration.

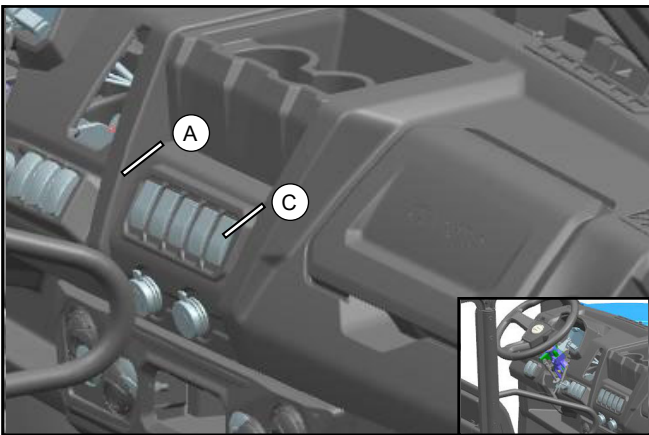

// Use a cutter to cut Switch Mount (C) for installing the switch of Wiper And Washer Assy.

**i** - Pay attention to use cutter correctly to avoid injury.

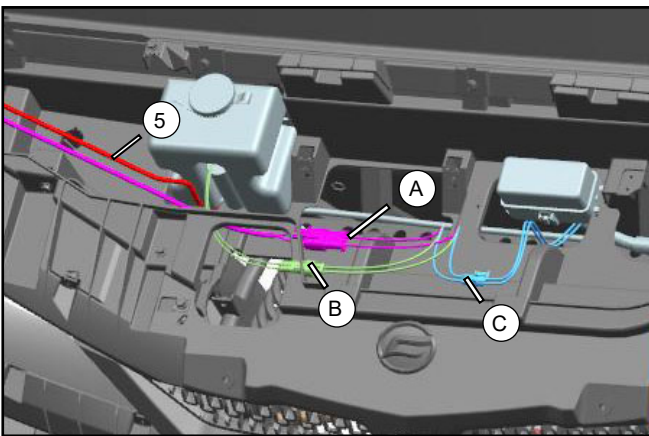

// Set up Harness and Washer Tube (5) as the left illustration, Pass switch cable (A) through the front fender and the switch mounting hole, and plug Connector (B) and (C) with Washer Tank cable port and Main Cable port.

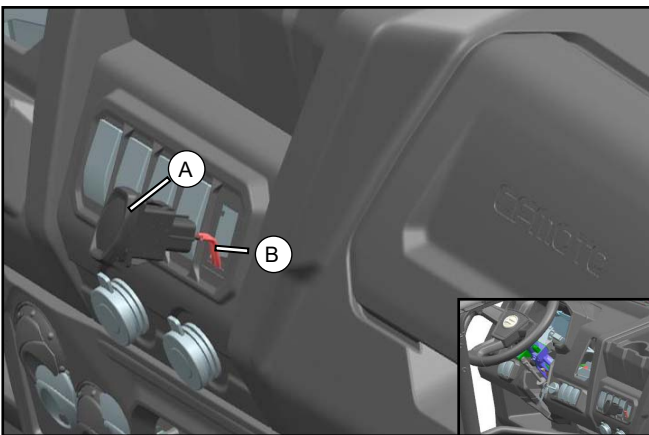

// Connect the Connector (B) of switch cable with switch (A).

## ASSEMBLY and INSTALLATION

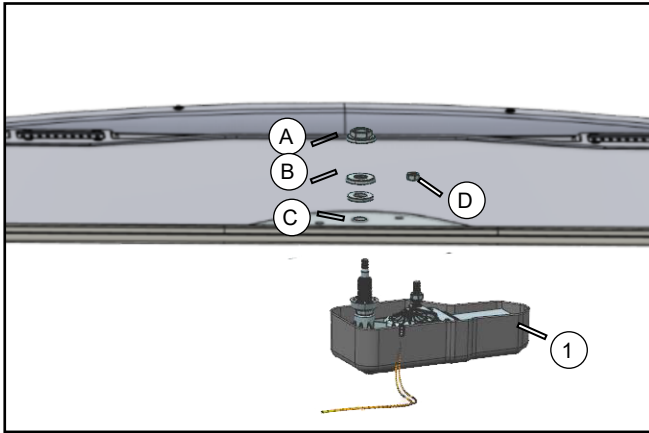

// Install Wiper Motor's M16 Nut (A), Cap Washer (B), Rubber O-Ring (C) and M8 Bolt (D) as the illustration.

**i** - M16 Nut (A), Cap Washer (B), Rubber O-Ring (C) and M8 Bolt (D) are contained on Wiper Motor.

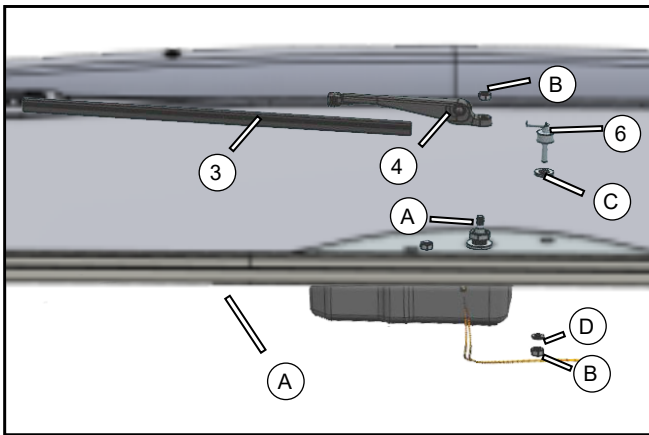

// Install Wiper Blade (3) on Wiper Arm (4), and tighten wiper on Wiper Motor with M8 Nut (B). Install Washer Tube Adapter (6) on front windshield with Rubber O-Ring (C), Washer (D), M8 Nut (B). Connect washer tube of Wiper Arm to washer tube adapter.

**i** - Rubber O-Ring (C), Washer (D), M8 Nut (B) are contained on Washer Tube Adapter.  
- Pay attention to adjust the angle of Wiper Arm and angle of washer tube adapter.

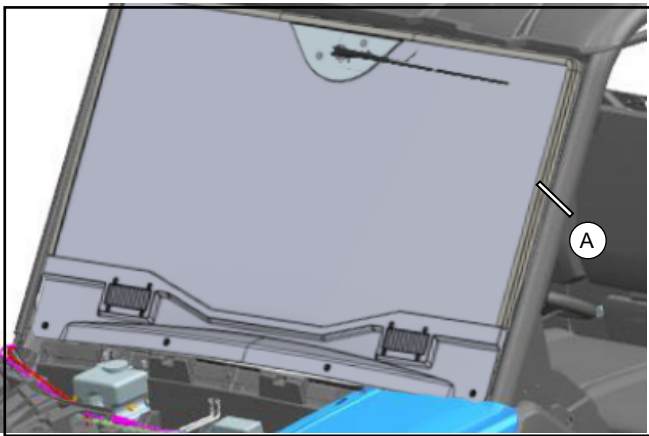

// Install front windshield on vehicle.

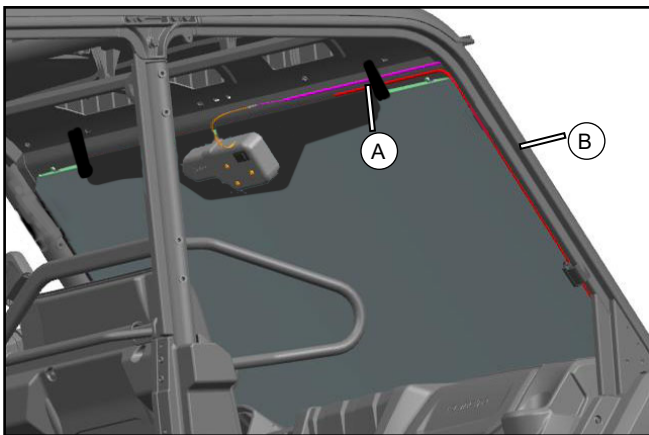

// Set up Washer Tube (A) through along ROPS as the illustration, use 3M double faced adhesive tape to stick wash tube, connect the tube with the adapter.

// Turn on the ignition and Wiper and Washer's switch, and press the button to check wiper and washer working. If works, turn off the ignition.

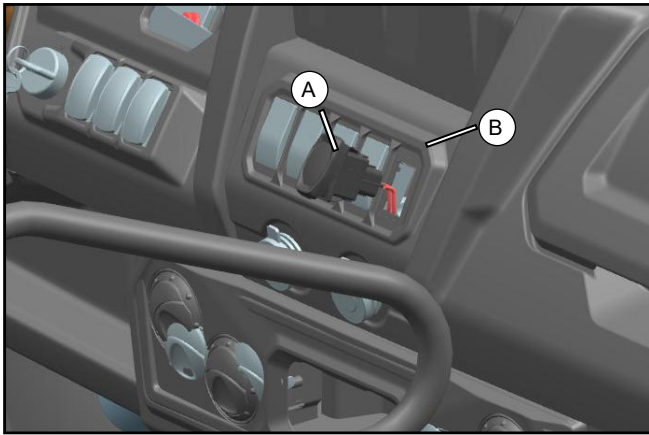

// Install Switch (A) on Switch Mount (B) correctly.

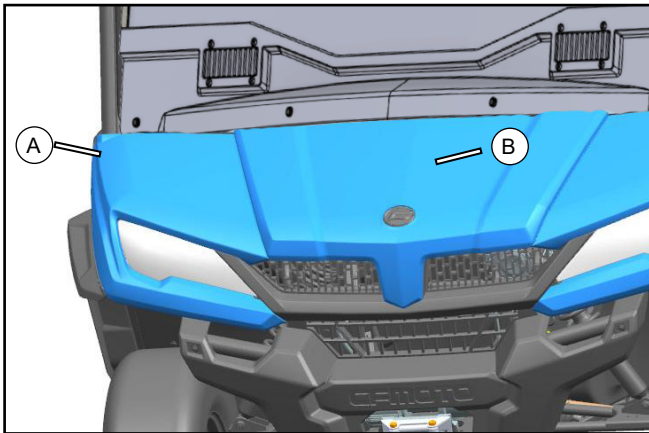

// Install Panel (A) and Front Hood (B) in sequence.